

Display section :
 PPI image by TFT liquid crystal color display

Frequency :
 21kHz, 24kHz, 28kHz

Display resolution :
 SXGA (1280X 1024)

Display colors :
 Sonar image -32-color display
 Character -4-color display
 Marker -2-color display

Display modes :
 Head-up, north-up, and true motion (*External signals are necessary)

Additional modes :
 Stabilization (± 20 -degree compensation) ,
 off-center (enlarged 1.5 times in a desired direction)

Simultaneous screen modes :
 Vertical section screen (1 direction, 2directions, enlarged screen) ,
 sonar 2 directions (lengthwise, crosswise) , memory image, audio image,
 sonar enlarged screen, multiple screen, fish finder image

Ranges :
 Any 15 ranges can be selected out of 150, 200, 250, 300, 400, 500, 600, 700, 800,
 900, 1000, 1200, 1400, 1500, 1600, 1800, 2000, 2500, 3000, 4000, and 5000.
 The range is enlarged 1.5 times for off-center. (Not available over 5000m)

Pulse width :
 0.5-200 msec

Receiving method :
 Super heterodyne method, real-time beam method, and forming method

Transmission method :
 OMNI transmission/Special transmission method

Audio frequency :
 800Hz(fixed)

Tilt angle range :
 3° upward-60° degrees downward

Section detection range :
 0° -60° downward

Beam (at 3dB) :
 Transmission-Horizontal 360° x 8°
 Receiving-Horizontal 13° x 11°

Additional functions :
 Interference elimination, signal processing, clutter, TVG, AGC, memory card,
 and auto tilt angle functions

Display marks :
 Own boat mark, wake mark, cross-line cursor, event mark (3 kinds, and max.
 10 event marks each) , direction mark, cast-net mark, tidal current mark and other
 marks. (*Some marks are displayed only when external signals are input.)

External signal input :
 NMEA0183 Four inputs available with NMEA 0183,
 NMEA0183 Own boat position, boat speed, boat speed bearing, seabed depth,
 sea water temperature, and bow bearing

Hoist unit stroke :
 LL=1500mm, L=1300mm

Power supply :
 Processing Single-phase 100~220VAC, 50/60 Hz, and 200VA
 Receiving Single-phase 220VAC, 50/60 Hz, and 600VA
 Sending 3-phase 220VAC, 50/60Hz, and 1500VA
 Hoist unit 3-phase 220VAC, 50/60Hz, and 1500VA

Measurement (W×H×D) & Weight :

I-133LCD	460mm×430mm×345mm	24Kg
RC-17 Remote Controller	246mm×158mm×46mm	1Kg
PRC-61B Processor	280mm×450mm×388mm	21Kg
TX-24 Transmitter	642mm×717mm×440mm	95Kg
RX-40 Receiver	617mm×754mm×448mm	90Kg
P-91 TX Power Box	440mm×490mm×250mm	34Kg
P-79B Power Box	215mm×335mm×153mm	12Kg
M-115C-LL Hoist	978mm×3700mm×837mm	945Kg

(with T-190 Transducer)

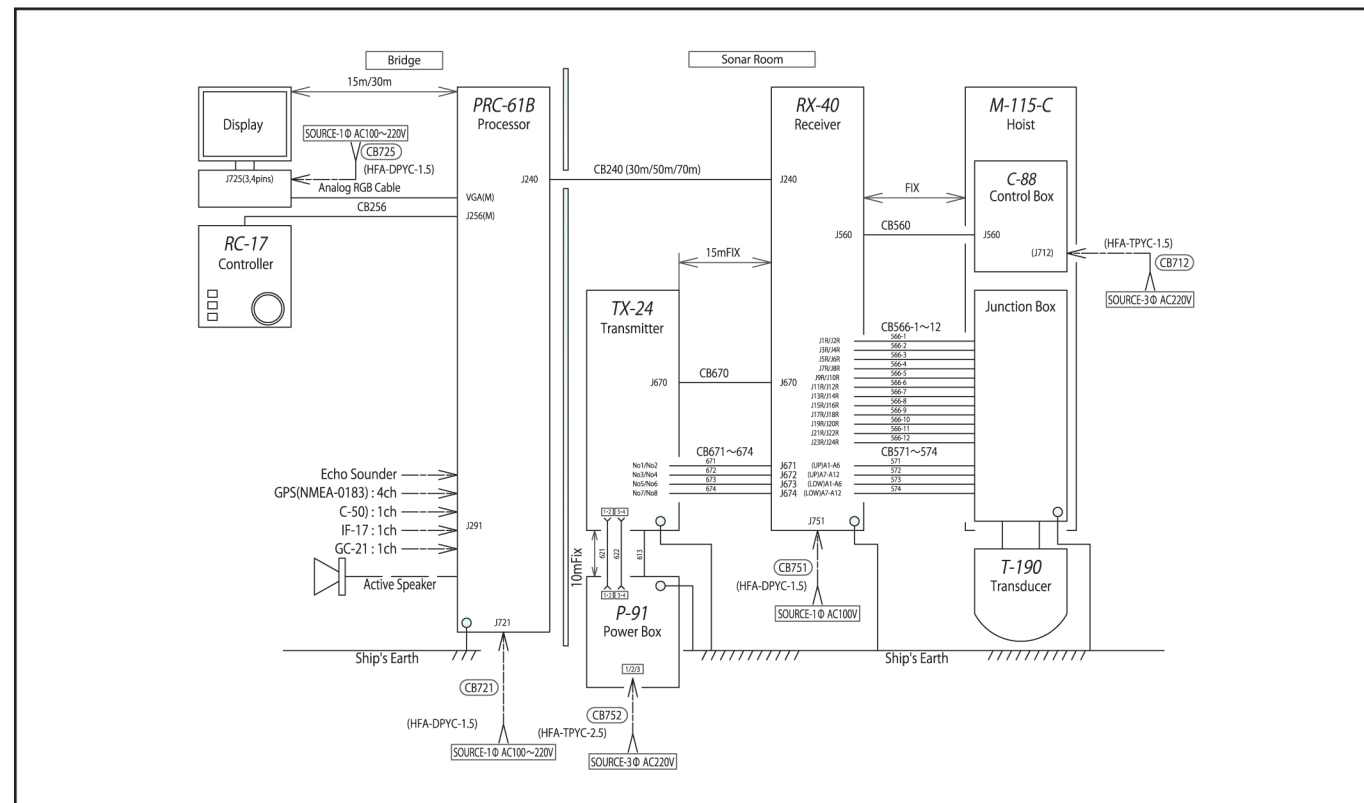

SAFETY PRECAUTION : Please be sure to read the Instruction Manual before operating
 ●Specifications are subject to change without prior notice for improvement.



TORKAR MARİN
 Elektronik Servis ve Ticaret A.Ş.

Ortaklar Cad. Nur Apt. No.:11 D:3
 34394 Mecidiyeköy - İSTANBUL
 Tel.: 90(212) 217 97 47-217 97 48
 Fax.: 90(212) 217 97 45
 e-mail: torkarmarin@dposta.net
 Web : www.torkarmarin.com

ISO 9001
 JQA-QMA13079
 MS JAB
 CM009

10-22, Higashimatsubara, Hakonegasaki, Mizuhomachi, Nishitama-gun, Tokyo, Japan 190-1295
 TEL: +81-42-568-3210 FAX +81-42-568-3310
 Email: info@u-sonic.co.jp URL: www.u-sonic.co.jp

SCS series
 Low frequency
Super Scanning Sonar
SCS-22

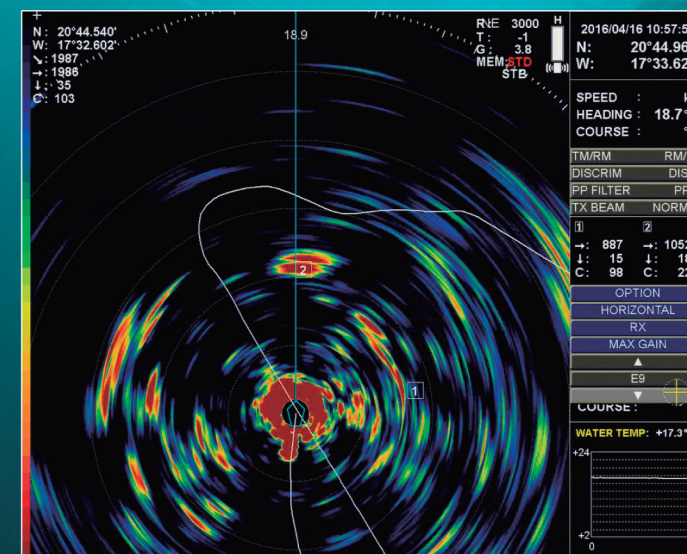

Valuable investments make unexpected profits.

Power is not the only quality needed to achieve good search results. Integration of all the following features will satisfy professional skippers, such as real effective power, minimized side-lobe, stabilization, and a precise display of the target.

- Different display modes can be selected depending on the distance, fish type, and fishing methods
- Desired image processing methods can be selected
- Unnecessary side-lobe is minimized to the lowest possible level
- User-friendly miniaturized controller
- Advanced TX/RX stabilizing function
- Strong, stable hoist unit with guide rings
- Reliable stainless cover for protecting transducer
- Advanced sectional image

Advanced vertical-section image and stabilization function

Changing the horizontal to vertical ratio of the sectional image clearly indicates the depth of a fish school. Together with an advanced stabilization function, the device displays no movement even when the ship pitches.

The stabilization function controls the depression angle in small 7.5 degree steps through 360 degrees for both transmission and reception. The processing time between the sensing of boat pitch to the adjustment of the depression angle has been dramatically reduced. The user can view highly.

The effect of stabilization

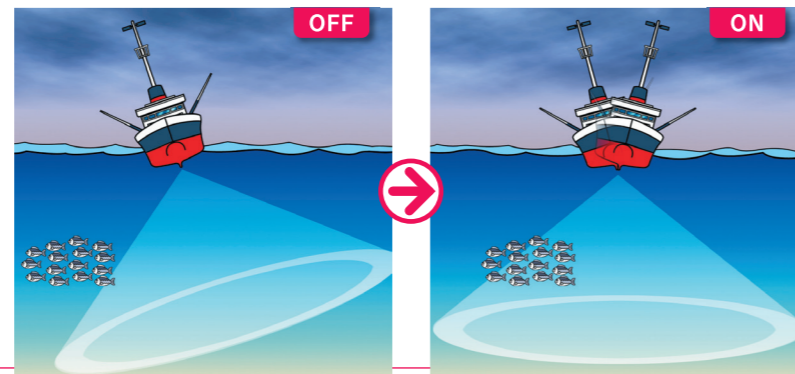

Avoid false response from side-lobe

Have you given up with removing false responses from side-lobe on rough sea surfaces or at shallow seabed? Sonic's devices are free from false responses. We guarantee sounds with minimum side-lobe.

The effect of sidelobe

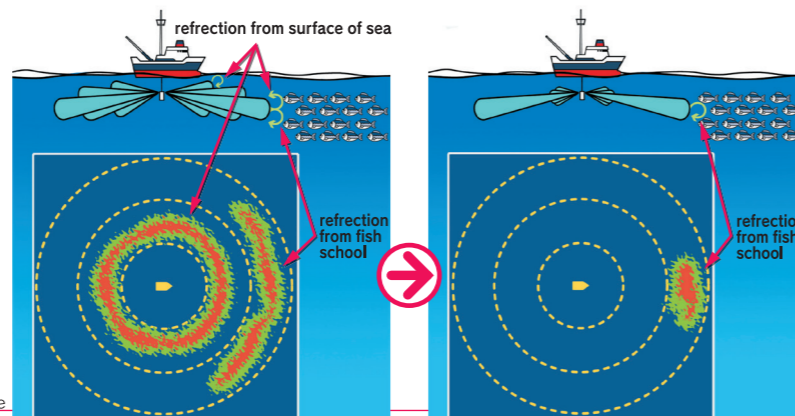

Safe and reliable transducer

All Sonic Hoists have a structure with guide rings in order to withstand the threats presented by the sea. Also, transducers are exposed to shocks in the sea. Sonic use a unique transducer covered with STAINLESS STEEL to protect it from damage.

※756elements inside of the transducer



Photo of transducer

High speed transmission cycle

High-speed image updating is essential in following fish movement. The device only takes 0.08 of a second from the last sound reception to the next transmission.

A high-speed vessel and the number of sonar transmission cycles are key points in catching up with fish.

SCS-22 sample pictures from real fishing grounds

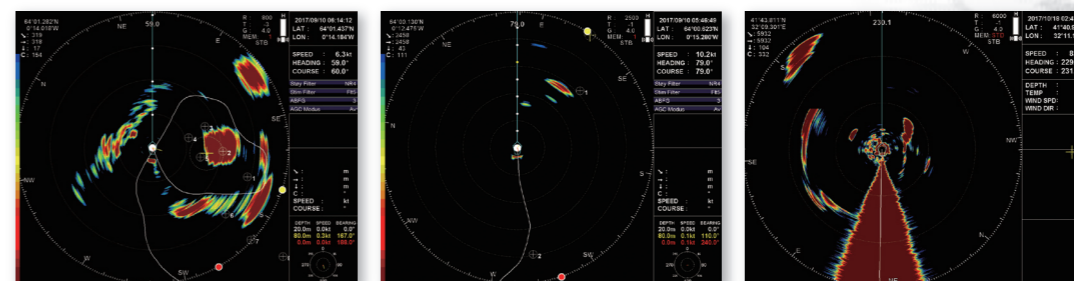

Mackerel at short range

Herring at medium range

Anchovy at long range